

# TRINOVA™

Dynamic Cushion and Mattress System

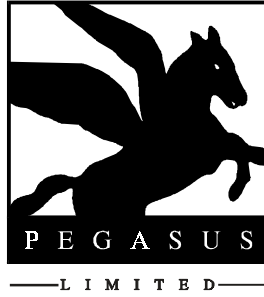

**User Guide**



## TRINOVA™ Dynamic Cushion and Mattress System



The **TRINOVA** Dynamic Cushion and Mattress System is suitable for patients showing any of the following characteristics:

- Assessed to be up to very high risk of pressure sore development.
- Require therapy to promote pressure sore healing.
- May have limited mobility but can be repositioned if necessary.
- Can sit out of bed for more than a few minutes.

The **TRINOVA** System reduces skin surface pressure at frequent intervals. This encourages the blood flow necessary to maintain healthy tissue, thereby giving therapy and prevention from pressure sores in vulnerable patients.

The mattress system offers a Step Down mode which is a static, lower pressure mode to assist in the assessment of patients whose condition continues to improve.

The system also offers comfort for the patient, firm side supports to facilitate bed/chair transfers and ease of use for the carer.

Patients who are immobile and/or cannot be repositioned when necessary, are therefore at greater risk and can be nursed on the **CAIRWAVE** Therapy System.

**NOTE:** Optimal performance is, in part, dependent on attaining a good seated position (chair height and posture), see Section I.

# TRINOVA

## CONTENTS

<b>SECTION</b>		<b>PAGE</b>
<b>A</b>	<b>GETTING STARTED</b>	4
	List of Parts	4
	Setting Up the Mattress and PMU	5
	Setting Up the Cushion	9
<b>B</b>	<b>PATIENT MANAGEMENT UNIT OPERATION</b>	12
	Front Panel Label	12
	Fast Inflate Mode	13
	Normal Mode	13
	Static Mode	13
	Step Down Mode	13
	Cardio Pulmonary Resuscitation (CPR)	14
	Cushion Connected	15
	Alarm Functions	15
	Transport Mode	16
	Profiling and Knee-breaking	16
<b>C</b>	<b>SYSTEM REMOVAL</b>	17
	PMU	17
	Mattress	17
	Cushion	18
<b>D</b>	<b>ALARMS AND FAULT FINDING</b>	18
	Alarm Function	18
	Fault Finding	18
<b>E</b>	<b>CLEANING</b>	19
	Mattress and Cushion Cleaning	19
	PMU Cleaning	20
<b>F</b>	<b>REPLACEMENT OF COVERS</b>	21
	Mattress and Airpipe	21
	Cushion and Airpipe	22
<b>G</b>	<b>USER SERVICING AND SERVICE</b>	23
<b>H</b>	<b>TECHNICAL DATA</b>	24
<b>I</b>	<b>USER POSTURE</b>	25

## SECTION A – GETTING STARTED

### LIST OF PARTS

Mattress

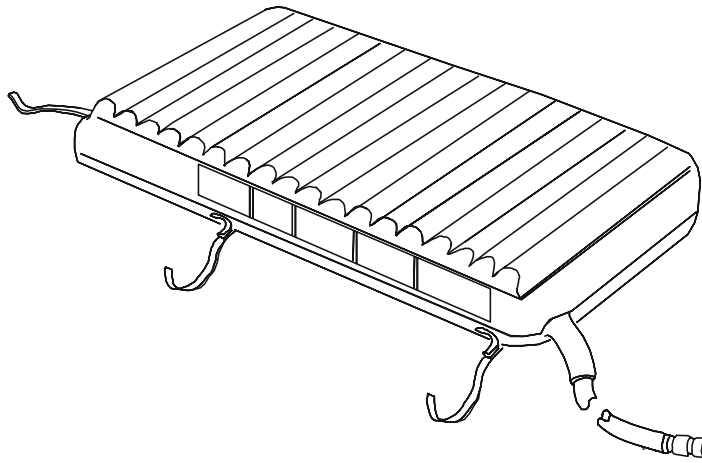

Cushion

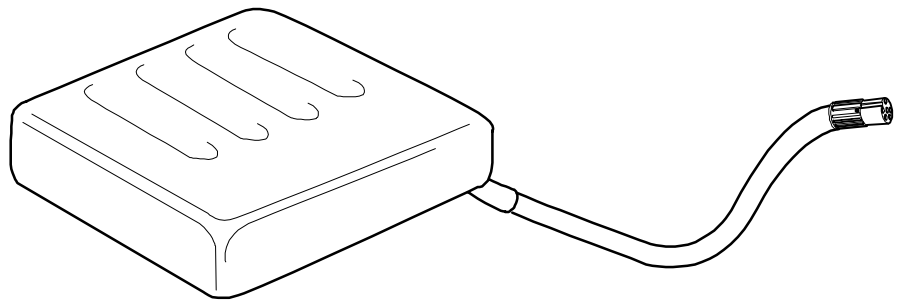

Patient Management Unit (PMU)

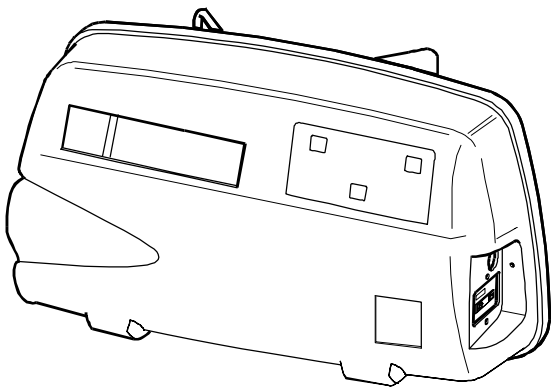

Power Lead

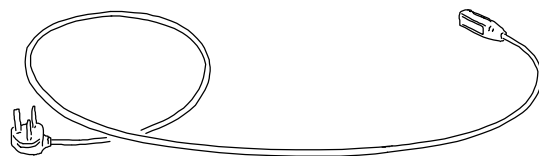

## SETTING UP THE MATTRESS AND PMU

1. Remove bed mattress.

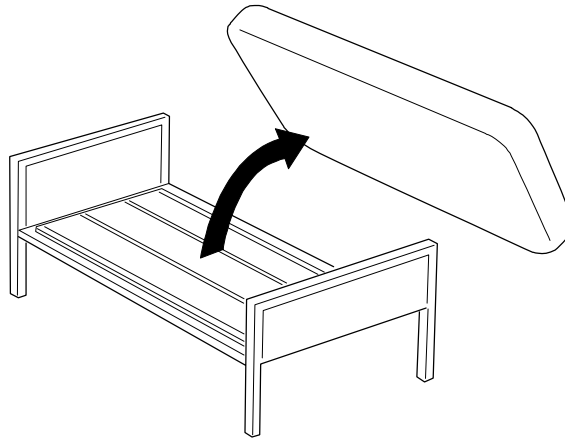

2. Place system mattress on bed - ensure there are no sharp objects to damage the mattress.

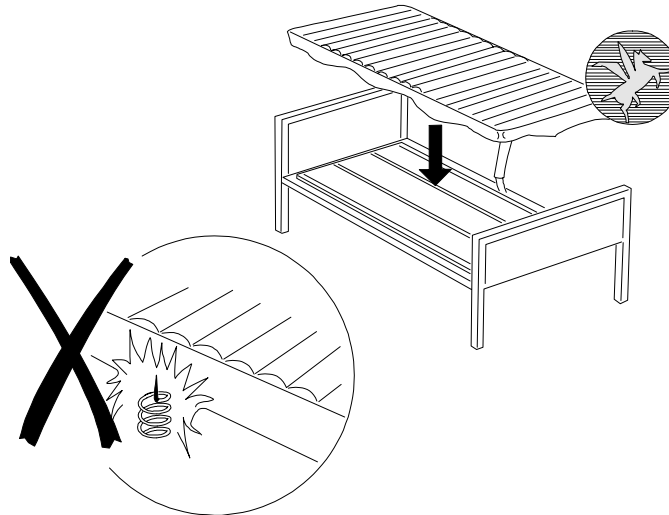

3. Secure mattress fixing straps loosely to moving parts of bed frame. Do not secure straps to removable head or foot boards.

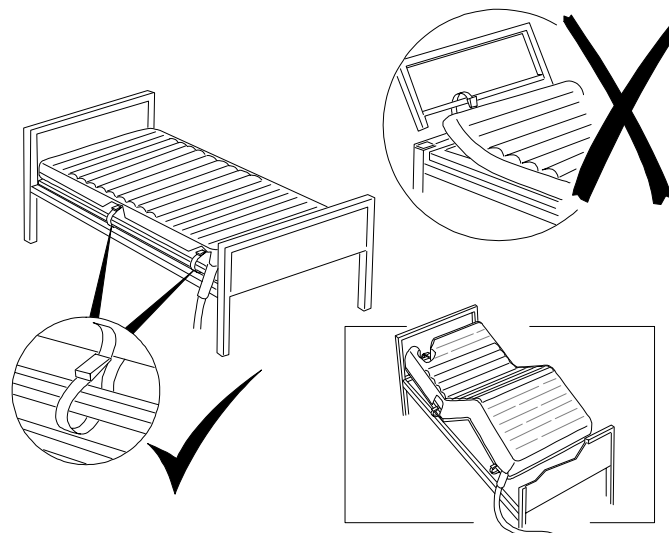

4. Connect mains lead and secure using the cable clamp.

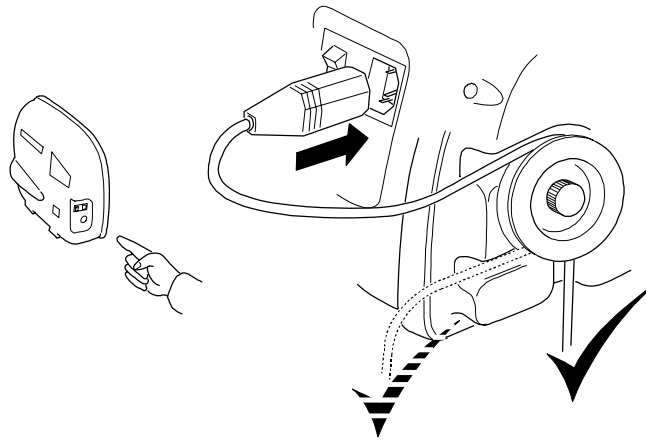

5. Hang PMU on foot of bed or place on floor.

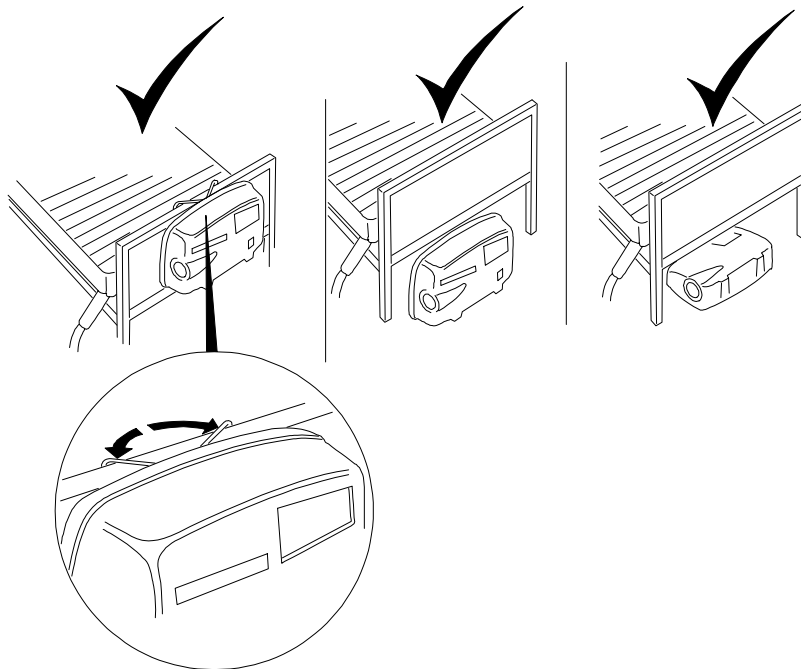

6. Connect airpipe connector and turn to 'normal' position.

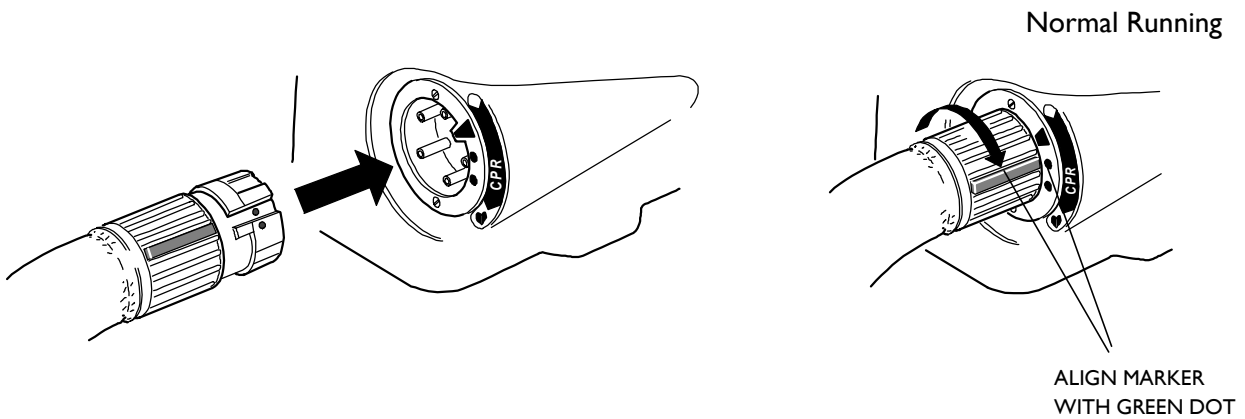

7. Plug Patient Management Unit (PMU) into mains socket and switch on. Alarm will beep 6 times and all lights will illuminate.

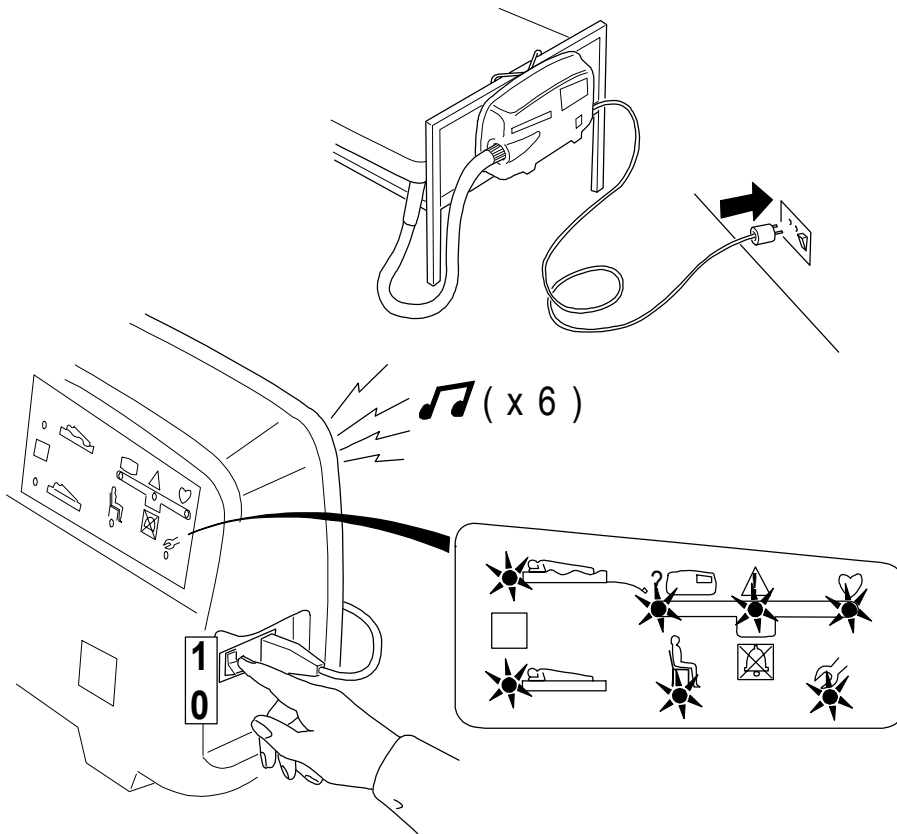

8. Check mattress is inflating (max 30 minutes) remove and check straps. During inflation 'Static' light will flash.

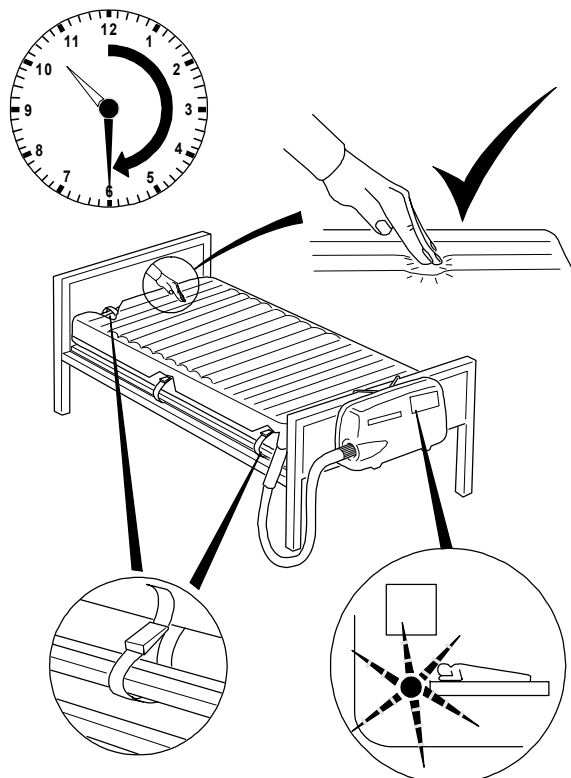

9. On completion of inflation, smooth cover, check and tighten straps.

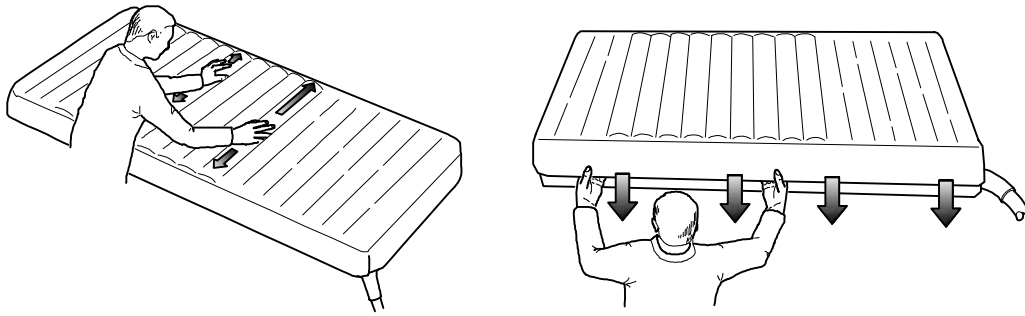

10. Place one sheet loosely over mattress. When ready for patient, 'Normal' light will illuminate.

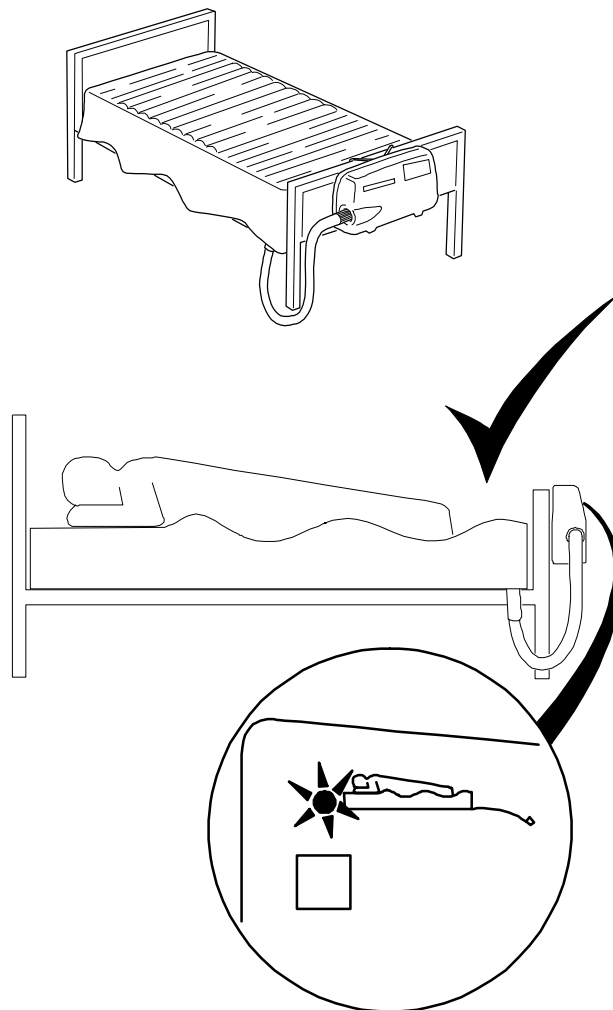



## SETTING UP THE CUSHION

### 1. If the system is not set up:

- a. Remove the chair cushion, check the chair base is in good condition and will support the patient.
- b. Place the system cushion on the chair base, ensuring it is pushed to the back of the chair.
- c. Connect the airpipe to the PMU, plug the PMU into the mains socket and switch on.

**NOTE:** The power unit can be mounted on the foot of the bed, or placed on the floor in a convenient position.

- d. Wait until the cushion is fully inflated and operating (cycling) correctly before use (approx 4 minutes).
- e. The Cushion Connected light will illuminate.

### 2. If the system is operating with the mattress connected:

- a. Disconnect the mattress from the PMU (the Check Air Connector light may flash and the audible alarm may sound).
- b. Connect the cushion.
- c. Wait until the cushion is fully inflated and operating (cycling) before use.

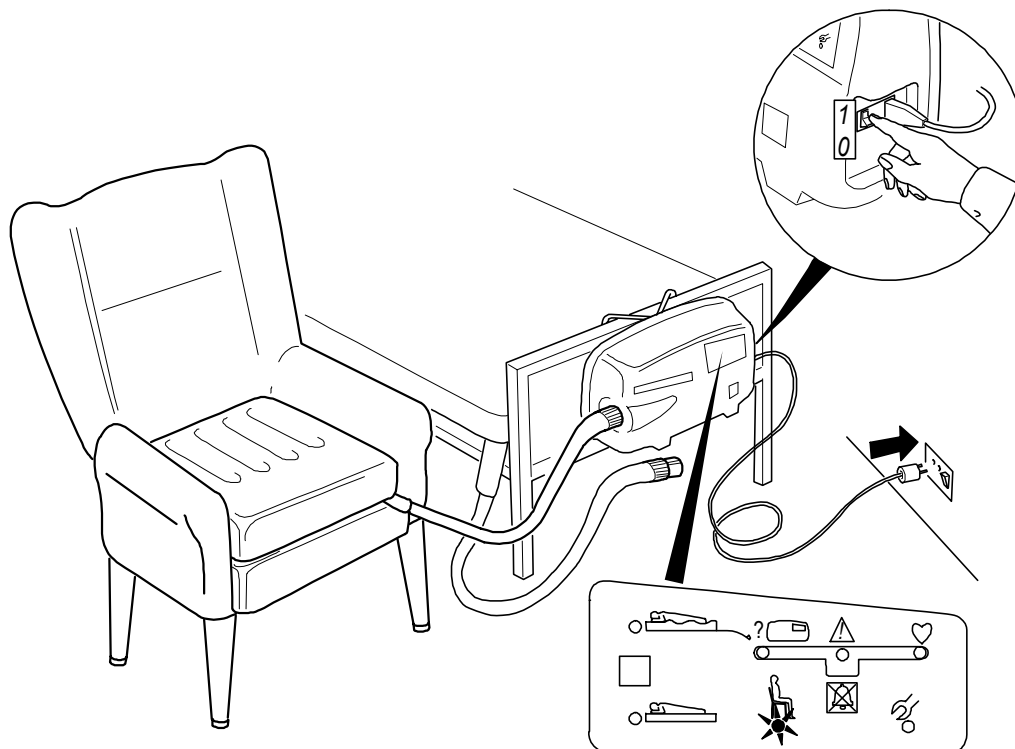

## Cushion disassembly

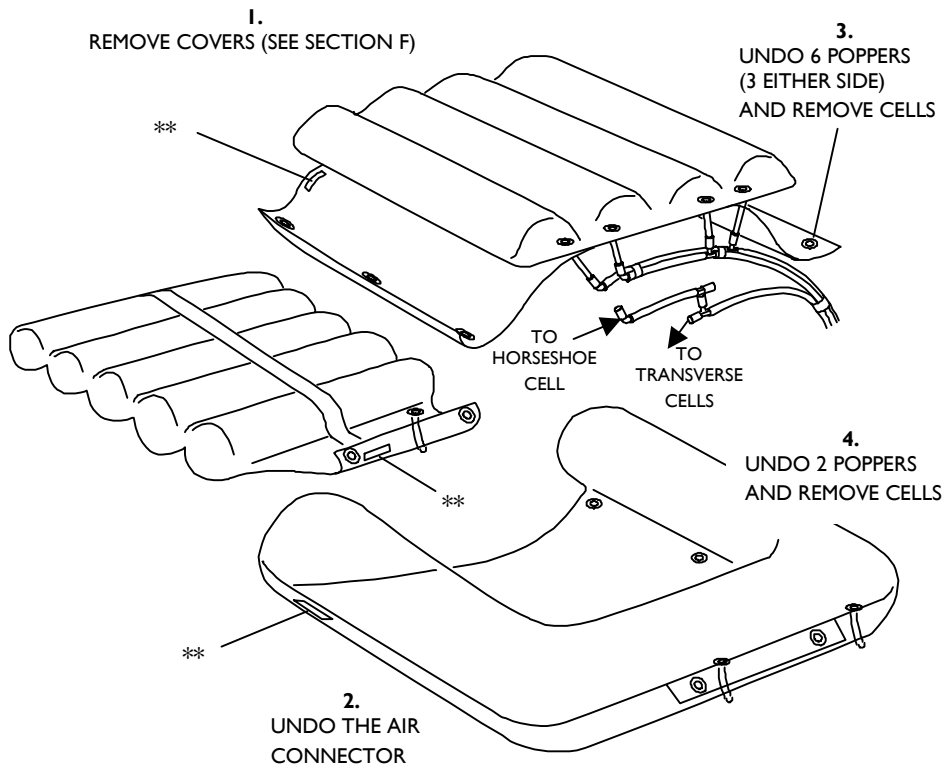

**NOTE:** Each inflatable part of the cushion has a serial number label (marked \*\*) attached for identification.

## Cushion assembly

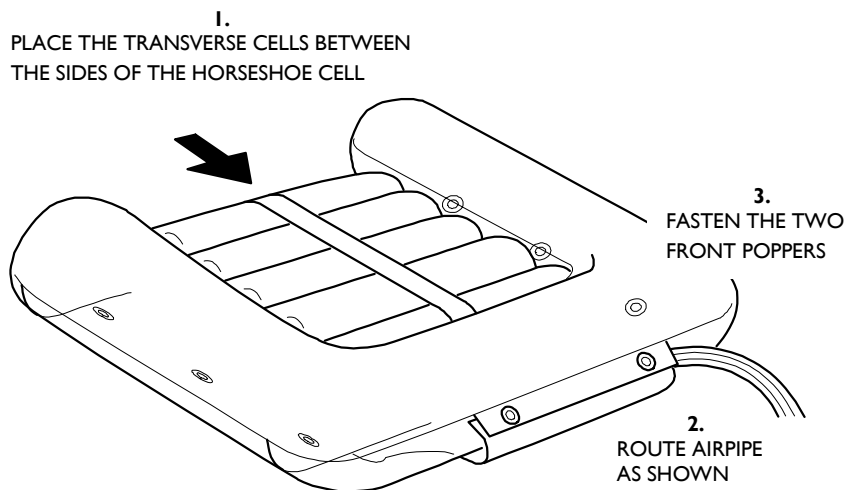

4.

PLACE SEAT CELLS ON TOP OF TRANSVERSE CELLS.  
PUSH THE WINGS UNDER THE HORSESHOE CELL.  
FASTEN THE SIX POPPERS

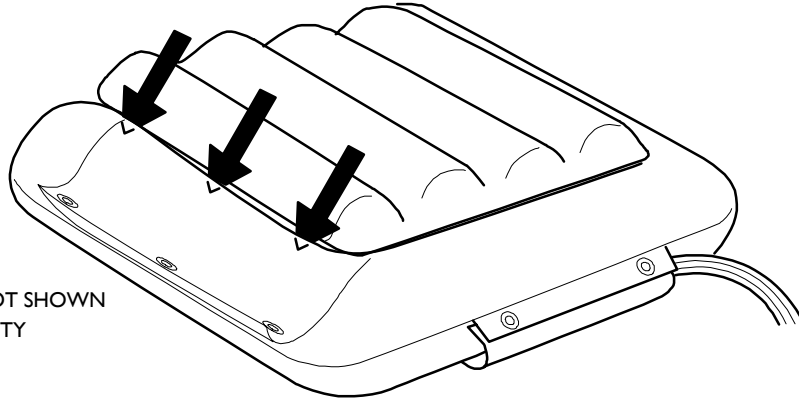

COVER NOT SHOWN  
FOR CLARITY

5.

ROUTE AIRPIPES AS SHOWN. REPLACE AIRPIPE COVER TYING TAPES AROUND THE SEAT CELL TUBING. GENTLY PULL THE CELL TUBING FORWARD TO ENSURE IT IS NOT UNDERNEATH THE SEAT CELLS (UNDO THE TWO FRONT POPPERS TO REPLACE THE COVER IF REQUIRED, ENSURING THEY ARE RE-FASTENED ON COMPLETION)

6.

RE-CONNECT CUSHION TO POWER UNIT AND INFLATE.

ENSURE SEAT CELLS ARE CENTRALISED, PULLING INTO POSITION IF REQUIRED

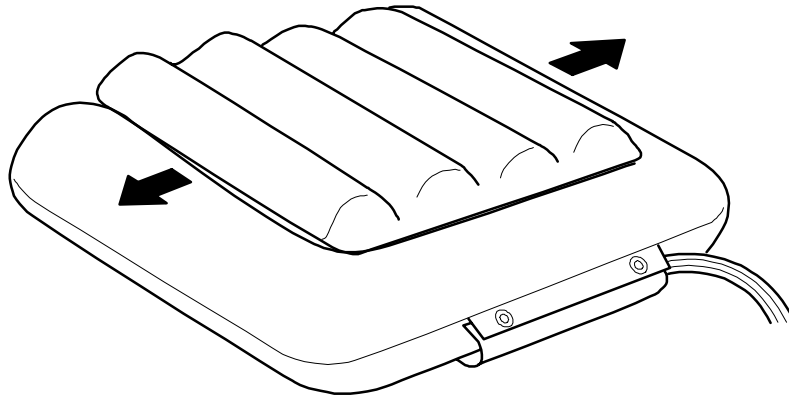

7.  
WHILE INFLATING, TURN THE CUSHION OVER.

BY LIFTING AND STRAIGHTENING THE BOTTOM SHEET AND MANIPULATING THE TRANSVERSE CELLS, ENSURE THE REAR OF THE TRANSVERSE CELLS ALIGN WITH THE REAR OF THE SEAT CELLS

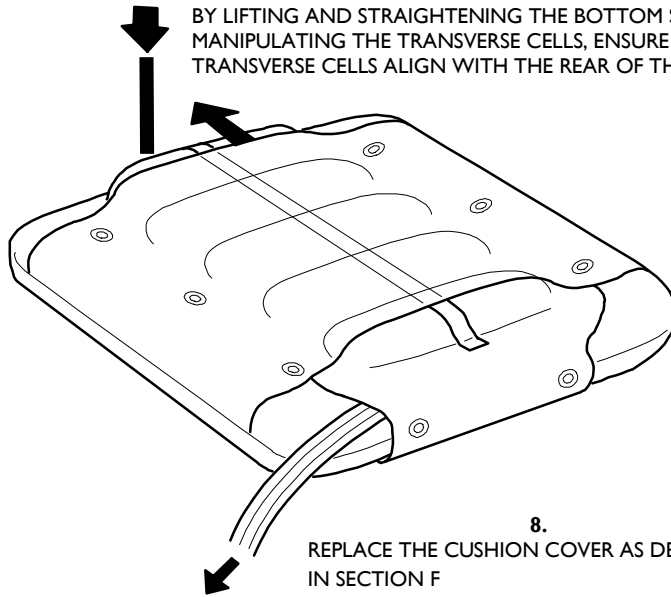

8.  
REPLACE THE CUSHION COVER AS DETAILED IN SECTION F

## SECTION B – PATIENT MANAGEMENT UNIT OPERATION

### FRONT PANEL LABEL

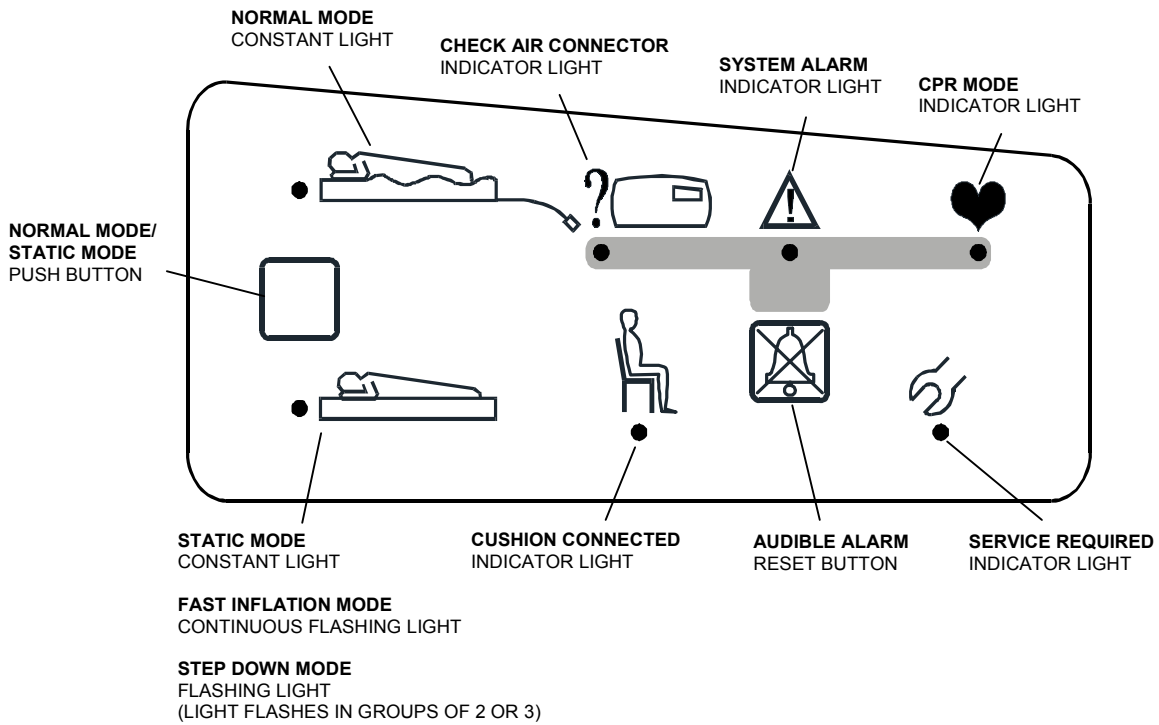

The PMU front panel both controls and indicates the various functions of the system and includes audible and visual indicators. The functions are described on the next page.

**FAST INFLATE MODE**  
(Fast Mattress Inflation)

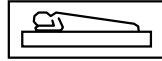

When switched ON with the air connector in Normal position and the mattress fully deflated, the system will automatically go into Fast Inflation Mode to ensure the mattress inflates quickly, allowing the system to be used in the shortest possible time (max 30 min). While the system is in Fast Inflate Mode, the amber Static Mode indicator light will continually flash.

If the system is switched ON with a partially inflated mattress, Fast Inflation will continue for a shorter period before reverting to Normal Mode.

**NORMAL MODE**  
(Normal System Operation)

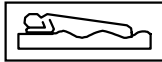

When the Fast Inflation Mode is completed, the system will automatically go into Normal Mode with the mattress cells inflating and deflating (cycling) and the green Normal Mode indicator light constantly illuminated.

**STATIC MODE**  
(Mattress not Cycling)



**WARNING:** The patient will not receive the full benefits of the system while it is in Static Mode, therefore the system should be returned to Normal Mode as soon as possible.

Some nursing procedures may require a static, fully inflated mattress. This is achieved by pressing the Normal/Static pushbutton to initiate Static Mode. A single beep will sound to indicate Static Mode is selected. Static Mode enables the PMU to inflate all cells fully and to maintain full inflation. When Static Mode is selected, the amber Static Mode indicator light will illuminate.

Static Mode runs for 30 minutes, after which it reverts to Normal Mode, unless an extension is made.

An alarm sounds after 25 minutes to warn of a return to Normal Mode.

To extend Static Mode for a further 30 minutes within the last 5 minutes, press the Normal/Static Mode pushbutton twice. If Static Mode is re-selected within the last 5 minutes, or up to 15 minutes after reversion to Normal Mode, the system assumes an extension has been made and will not allow a further extension.

Only one extension is allowed and Static Mode cannot be selected for 30 minutes after the extension is finished.

**NOTE:** You can toggle between Normal and Static Modes by pressing the Normal/Static Mode pushbutton, unless it is within 30 minutes of a Static Mode extension.

**STEP DOWN MODE**  
(Mattress not Cycling)



Enables a patient assessment to be made of the requirement for continued use of the system. Step Down Mode can only be selected when in Normal or Static Modes.

To start or stop Step Down Mode, press and hold the Alarm Reset and Normal/Static pushbuttons at the same time until a beep is heard. When Step Down Mode is selected, the mattress becomes static and the pressure automatically reduces.

Step Down Mode has High and Low pressure settings. To toggle between the two settings press and hold the Normal/Static Mode pushbutton once each time until a beep is heard. The pressure selected can be seen by the Static Mode LED flashing in groups of two (low pressure) and three (high pressure) flashes.

To ensure a regular check is made of the patient and the nursing staff are aware of the system being in Step Down Mode. An alarm will sound after 2 hours in groups of 2 or 3 beeps depending on pressure selected and will continue to sound at regular intervals. The alarm can be cancelled by pressing the Alarm Reset pushbutton but will sound again after 2 hours.

**NOTE:** While in Step Down Mode, the patient only receives pressure care equivalent to a quality pressure redistributing foam mattress.

## CARDIO PULMONARY RESUSCITATION (CPR)



In the event of cardiac arrest, turn the air connector to the CPR position. The mattress will immediately begin to deflate.

FOR RAPID DEFLATION  
TURN CONNECTOR FULLY  
IN DIRECTION OF ARROW  
**(DO NOT DISCONNECT)**

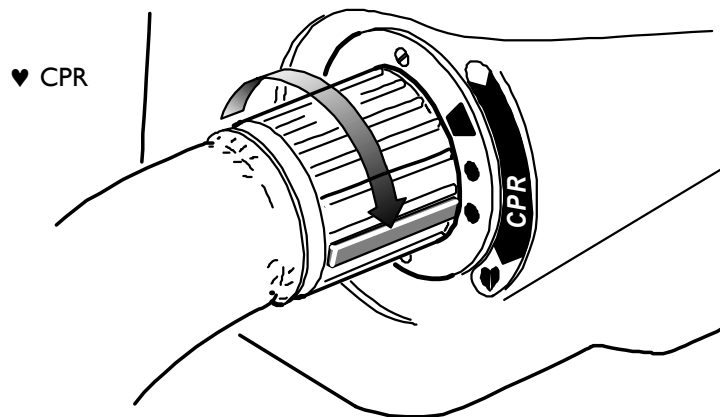

When the connector is turned to the CPR position the alarm will sound for a few seconds and the red heart will flash. The flashing red heart will cancel when CPR is no longer selected or if the Patient Management Unit (PMU) is switched off.

If CPR is required while the bed is being moved and the system is in Transport Mode, ensure the connector is disconnected from the PMU, turn the air connector to the deflate position. This will allow the mattress to deflate to enable CPR to be carried out.

Deflation or ♥ CPR during Transport

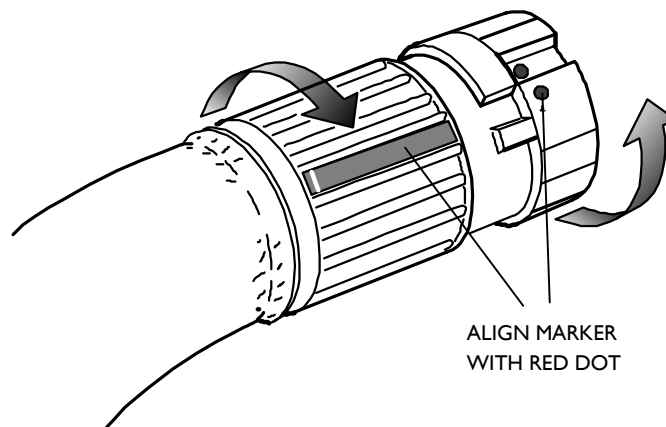

## CUSHION CONNECTED



When the cushion is connected in place of the mattress, the cushion indicating light will illuminate and all other lights will extinguish.

## ALARM FUNCTIONS

### CHECK AIR CONNECTOR INDICATOR LIGHT



The amber Check Air Connector indicator light will flash when the air connector is not correctly in place or is in the Transport Mode with the PMU turned on.

### SERVICE REQUIRED INDICATOR



The amber Service Required indicator light will flash after 10,000 hours of use, when a routine system service is recommended - contact the Service Organisation. The system will continue to function normally whilst in this state.

### SYSTEM ALARM



The red System Alarm indicator light will flash and the audible alarm will sound if there is a system fault.

There will only be an audible alarm:

1. Every 2 hours when in Step down Mode.
2. Within the last 5 minutes of Static Mode.
3. If the air connector is disconnected.
4. For 10 seconds when CPR is selected.

The System Alarm indicator light can only be reset by turning off the PMU.

### ALARM RESET BUTTON



Resets the audible alarm when pressed.

All alarms other than the power down alarm will return after 30 minutes if no corrective action is taken.

## TRANSPORT MODE

(Mattress not Cycling)

**WARNING:** The patient will not receive the full benefits of the system while it is in Transport Mode. Therefore the system should be returned to Normal Mode as soon as possible.

**NOTE:** Prior to disconnecting the mattress for transport, it is recommended that Step Down Mode is selected to provide support for the patient during transport (for Step Down Mode, see page 11).

When moving the bed with the mattress still inflated, or in the case of power failure, turn the air connector to the Transport position and disconnect. This will maintain the cells in their present state for approximately 24 hours.

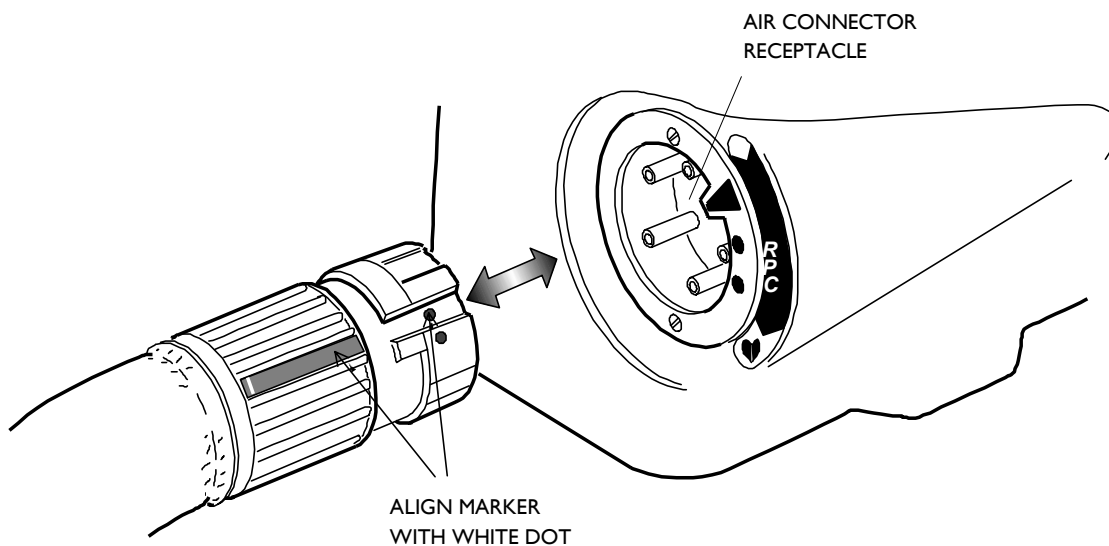

Unit Connection/Disconnection (Transport)

The amber Check Air Connector indicator light will flash and the audio alarm will sound until the Patient Management Unit (PMU) is switched OFF.

Turn OFF the PMU and unplug from the mains supply. An audible alarm will sound - cancel the alarm by pressing the Alarm Reset pushbutton. The bed can now be moved.

When the bed has been moved to its new location, connect the PMU to the mains supply as soon as possible and turn ON. Reconnect the air connector and turn to the Normal position.

The system will restart in Fast Inflation Mode, then automatically revert to Normal Mode.

## PROFILING AND KNEE-BREAKING

The system may be used while the bed is in the profiled or knee-break position:

1. With the bed in its present position, loosen the mattress securing straps.
2. Change the bed to the required position (profiled or knee-break).
3. Re-tighten the securing straps.



## SECTION C – SYSTEM REMOVAL

### PATIENT MANAGEMENT UNIT

Switch off, silence alarm, disconnect from mains.

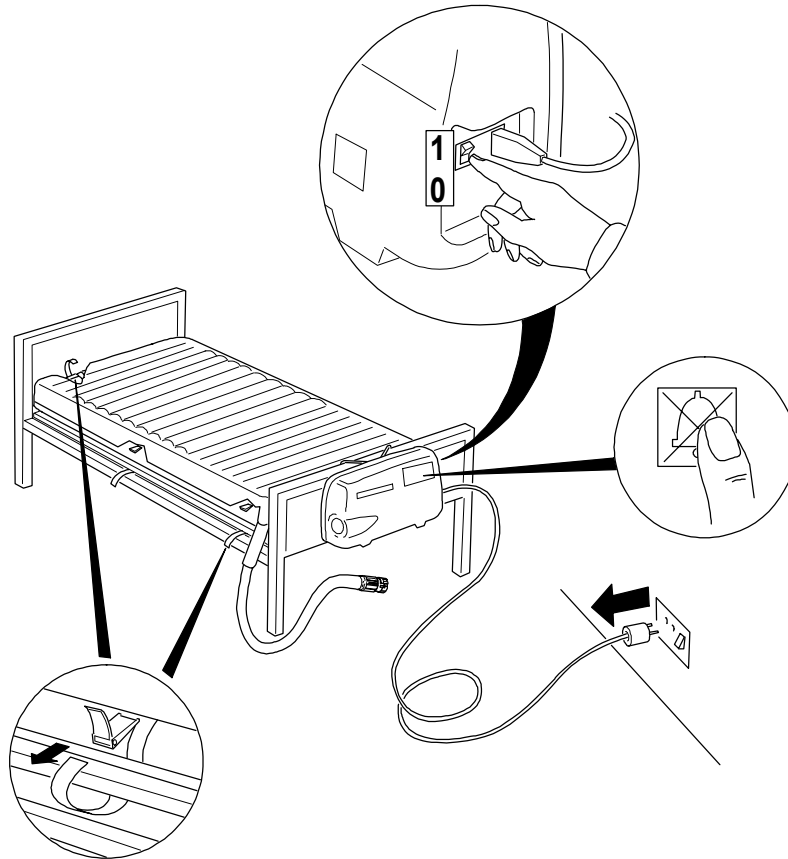

### MATTRESS

Disconnect airpipe connector and turn to deflation position.

Roll up mattress.

Remove PMU.

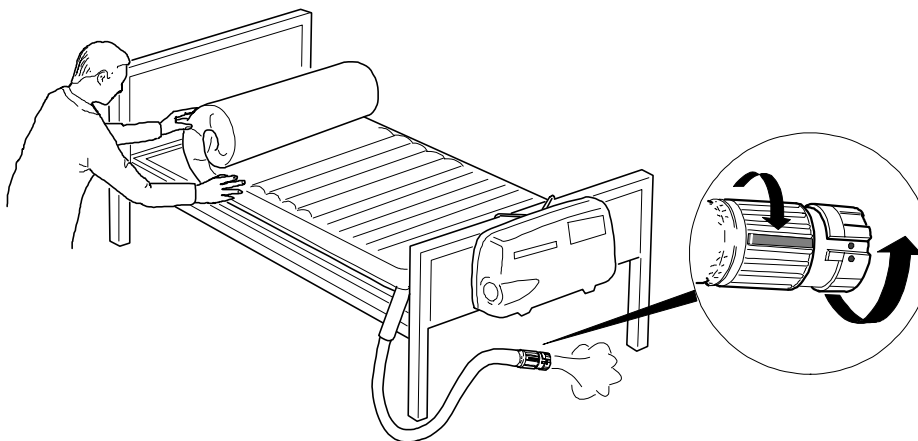

## CUSHION

Disconnect airpipe connector (remove cushion from chair if required).

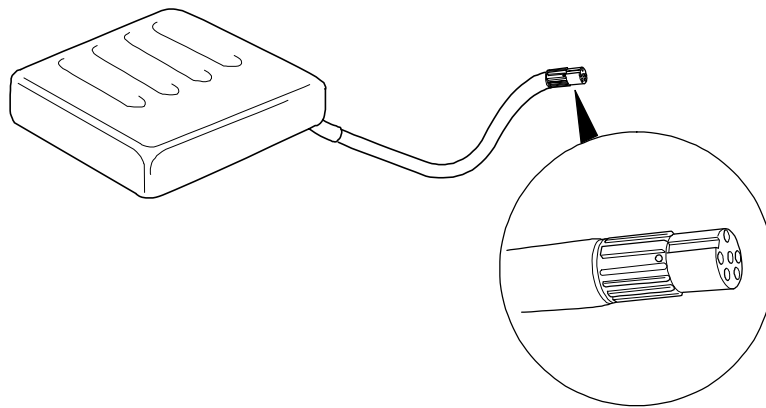

## SECTION D – ALARMS AND FAULT FINDING

### ALARM FUNCTION

The System has audible and visual indicators to alert the user to the system status.

In normal conditions with mains power available, the Patient Management Unit (PMU) turned on and the mattress fully inflated and cycling, the Normal Mode indicator light on the PMU front panel will be green and the mains light on the switch socket illuminated.

If at any time the mains power should be removed from the PMU, an audible alarm will be heard. The audible alarm may be cancelled by pressing the Alarm Reset Pushbutton on the PMU.

Should your system develop a fault whilst in use, the System Alarm indicator light will turn red and an audible alarm will be heard. This alarm may be cancelled by switching OFF the PMU and then pressing the Alarm Reset Pushbutton.

**NOTE:** The red fault light may flash in a series of two, three, four, five or six flashes. This is to assist the supplier when contacted about the fault.

### FAULT FINDING

SYMPTON	ACTION
No lights on PMU	Check PMU is connected to the mains power supply and that the PMU mains switch is turned ON.
'Check Air Connector' indicator light flashing and alarm sounding	Reset audible alarm by pressing the Alarm Reset Pushbutton. Check air connector is connected and turned to the Normal position. The Check Air Connector indicator light will automatically go out.

## SECTION E – CLEANING

### MATTRESS AND CUSHION CLEANING

It is recommended that the system is cleaned regularly and after each patient use.

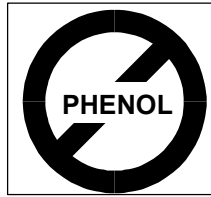

#### CAUTION:

#### Cleaning guidelines

In many cases it will only be necessary to remove the mattress top cover or cushion cover for cleaning. Where there is obvious soiling a full cleaning or sterilization procedure will have to be carried out.

Ensure fully dry before use.

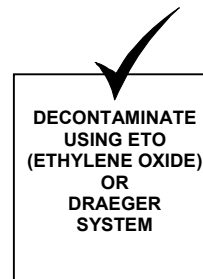
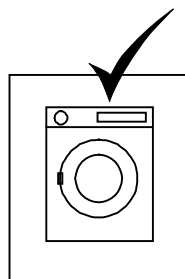
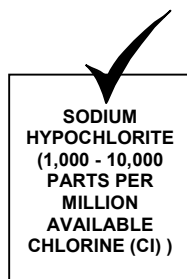
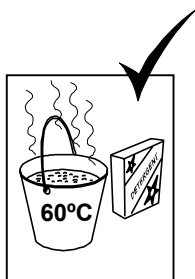
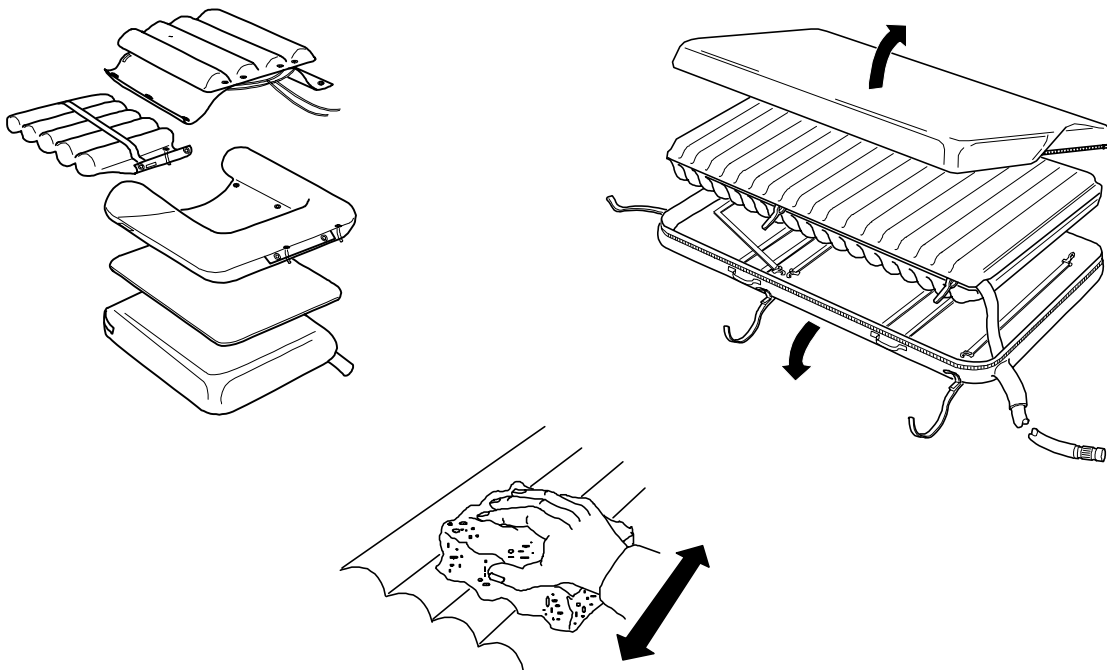

COVER ONLY



# PATIENT MANAGEMENT UNIT CLEANING

**CAUTION**

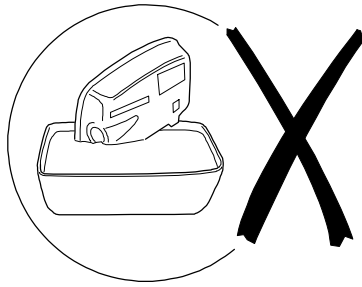

## Cleaning guidelines

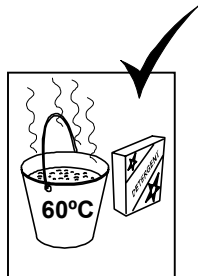
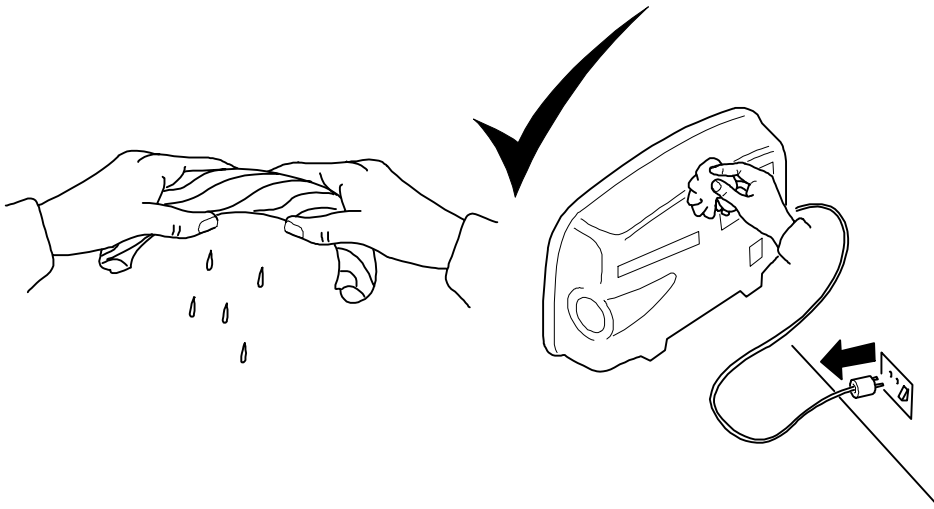

**SODIUM  
HYPOCHLORITE  
(1,000 - 10,000  
PARTS PER  
MILLION  
AVAILABLE  
CHLORINE (C) )**

**DECONTAMINATE  
USING ETO  
(ETHYLENE OXIDE)  
OR  
DRAEGER  
SYSTEM**

## SECTION F – REPLACEMENT OF COVERS

### MATTRESS AND AIRPIPE

Fully unzip the cover and remove the top section.

Release the strap securing the airpipe cover to the mattress pipes and remove the airpipe cover.

Undo the 6 clips securing the mattress to the cover bottom section, pull the airpipes through the sleeve in the cover and lift the mattress out of the cover bottom section.

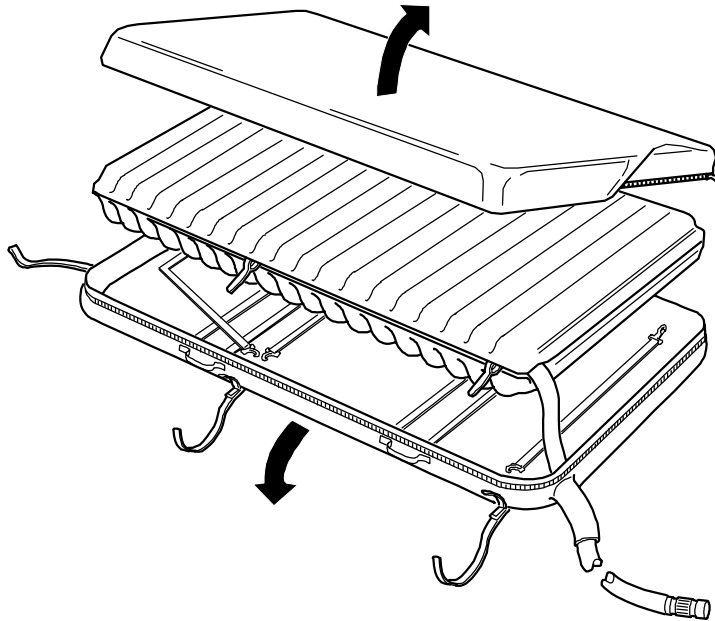

Replacement is the reverse of the above, with the following additions:

To ensure the cover sits over the mattress snugly, when the mattress is inflated pull down on the top cover sides to straighten the cover, then smooth down.

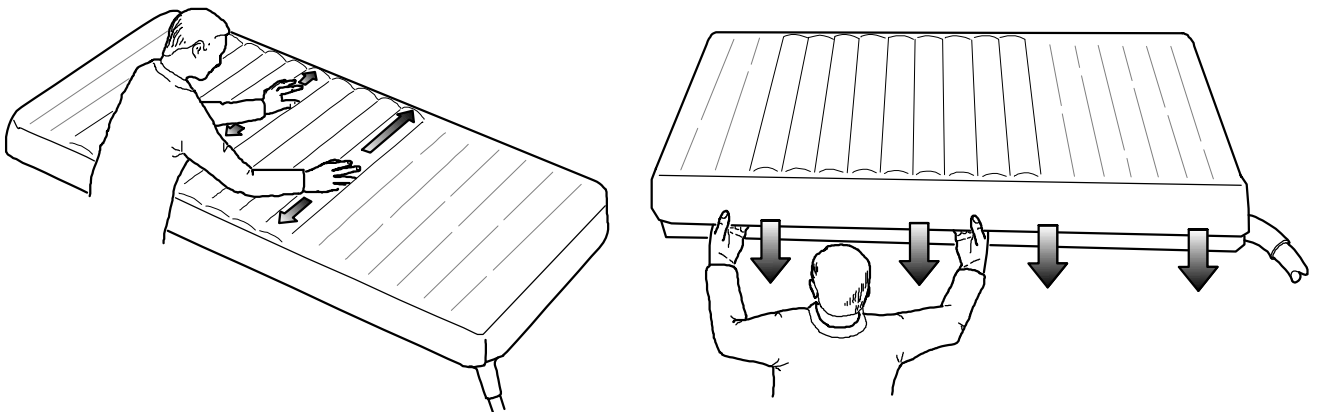

## CUSHION AND AIRPIPE

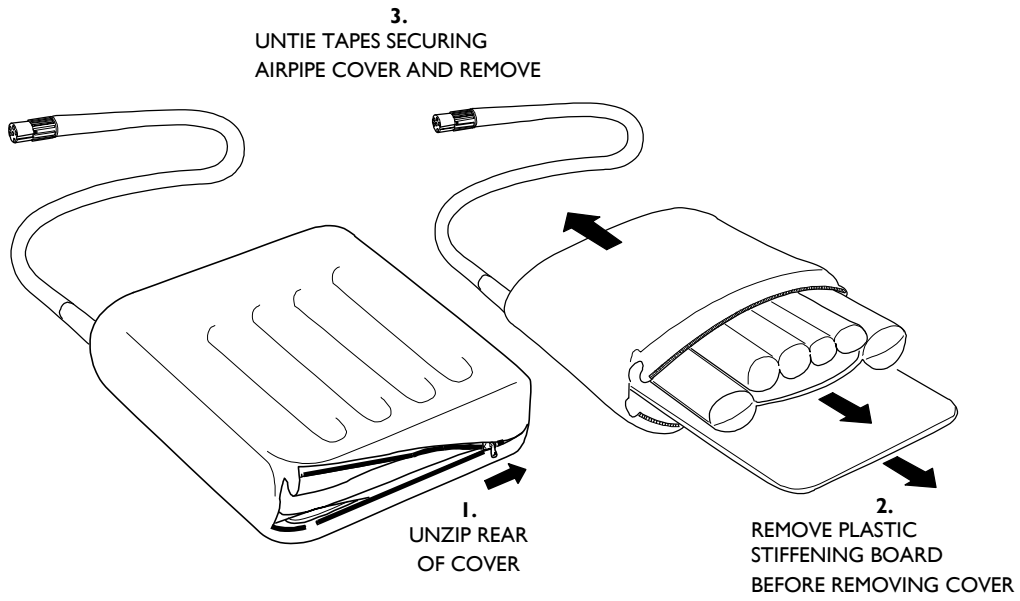

**NOTE:** When fitting the airpipe cover, ensure the elasticated end fits fully into the groove on the air connector. Loosely refit the strap around the internal pipes.

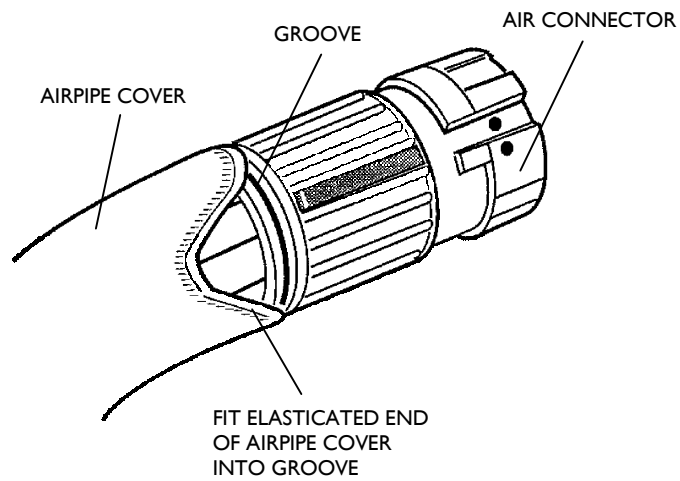

## SECTION G – USER SERVICING AND SERVICE



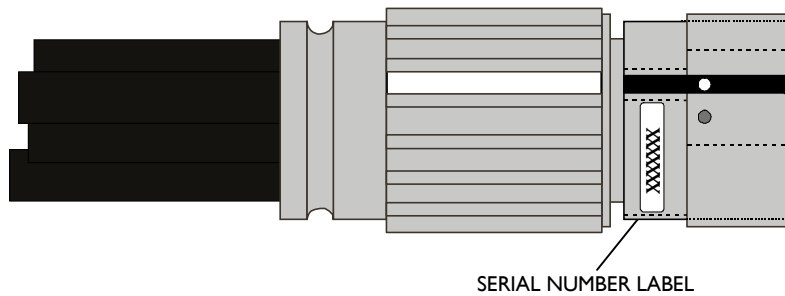
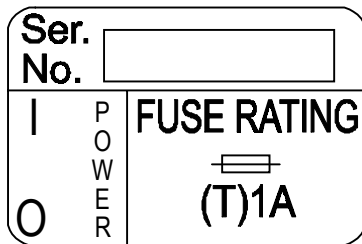

The system has been designed for ease of use and contains no user serviceable items.

If you have any queries about the operation of the system contact your supplier.

To help identify your system when telephoning, please make a note of the unit serial numbers which you will find on the label by the PMU mains switch, on the label on the rear of the PMU, or on the air connector of the mattress and cushion.



## SECTION H – TECHNICAL DATA

Cycle Control	Purpose designed distributor valve supplying operating air to the inflatable cells		
Cycle Time	7.5 minutes (mattress and cushion)		
Supply Voltage	220/240Vac 50Hz		
Power Rating	Maximum 40VA		
Fuse Rating	1A Antisurge (x2)		
Noise Level	NC30		
Nominal Dimensions	Mattress (Inflated)	Cushion (Inflated)	Patient Management Unit
	1930mm long	450mm deep	120mm deep
	880mm wide	500mm wide	400mm wide
	210mm high	125mm high	210mm high
	Weight 9.5kg	Weight 2.5kg	Weight 3.5kg
Electrical Safety	Conforms to BSEN 60601-1		
Classification	Class 1, Type B		
Mode of Operation	Continuous		
Symbols	   	<p>Fused with two 1A Antisurge Fuses</p> <p>Alternating Current</p> <p>Mains Switch - 1 (On) Power connected to the mains supply 0 (Off) Power disconnected from mains supply</p> <p>Type B</p>	
Environment (Usage and Storage)	<p>Air Humidity: 30% to 75%</p> <p>Ambient Temperature: 0°C (32°F) to 40°C (104°F)</p>		
EMC	This equipment complies with EMC requirements. If effects are noticed the affected equipments should be moved apart.		



This product carries the CE mark in accordance with EC Directive on Medical Devices (93/42/EEC).

Pegasus Limited cannot be held responsible for any damage caused to our products (by foreign objects – needles, sharps, eating utensils, etc) other than due to normal wear and tear as defined in the product warranty agreement. Nor for any injury or incident which relates to the use of cot sides, profiling or any other mechanical or electrical device used in conjunction with this product unless supplied and/or manufactured by Pegasus Limited.



## SECTION I – USER POSTURE

### USER POSTURE

To provide optimum protection and therapy, ensure the user is provided with a chair at the correct height to encourage a good seated posture.

NORMAL SITTING POSITION

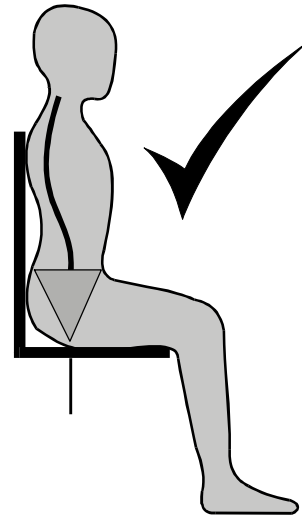

For those who have difficulty with posture e.g. muscular or skeletal abnormalities or those who have persistent lateral shift please contact your Pegasus representative or an appropriate Health Care Professional for advice.

PELVIC OBLIQUITY WITH RESULTANT SCOLIOSIS

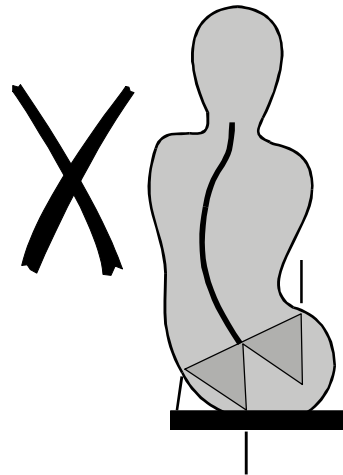

## NOTES

## NOTES



## **PEGASUS LIMITED**

Pegasus House

Waterberry Drive Waterlooville Hampshire

PO7 7XX England

Tel: +44 (0) 23 9278 4200

Fax: +44 (0) 23 9278 4250

E-Mail: [custserv@pegasus-uk.com](mailto:custserv@pegasus-uk.com)

Website: [www.pegasus-uk.com](http://www.pegasus-uk.com)

## **PEGASUS**

and the associated device marks are Trademarks of Pegasus Limited.

Pegasus Limited has a policy of continuous product improvement and reserves the right to amend specifications presented in this brochure.

